

2

WIOARR  
AEGIA

POWER AMPLIFIERS

# INTRODUCTION

Welcome to Vidar 2...or Aegir 2! This manual covers both products. Both are true, no-excuses, linear supply, heavy-as-heck power amps. And, at the same time, both have an eye to the future, with full microprocessor management for better performance and safety. And we've even added a super-smart standby mode that cuts power consumption to just a watt or two, while keeping the amp ready for great sound. We hope you really enjoy this marriage of old and new!



The following is required by the roughly 9,542 government agencies and regulations we have to comply with. If you have some common sense, they should seem pretty straightforward. In any case, read these instructions before proceeding farther, follow all instructions, and heed all warnings. Or else!

1. If you don't know how to install audio devices, get a qualified professional to help.
2. Never use this device near water, and clean only with a dry cloth.
3. Assure adequate ventilation, do not block any ventilation openings, or place near heat sources.
4. Use only the supplied power cord or suitable replacement. Route cords away from traffic areas and protect them from being pinched. Unplug the cord from the outlet if the apparatus is unused for a long period of time.
5. To prevent electric shock, do not use the plug with an extension cord, receptacle, or outlet unless blades can be fully inserted.
6. Refer all servicing to qualified service personnel. Service is required when the device has been damaged, including cord or plug damage, liquid has been spilled or objects have fallen into the device, the device has been exposed to rain or moisture, does not operate normally, or has been dropped.



**WARNING: TO REDUCE THE RISK OF FIRE OR ELECTRIC SHOCK, DO NOT EXPOSE THIS DEVICE TO RAIN OR MOISTURE.**

## STEREO CONNECTION

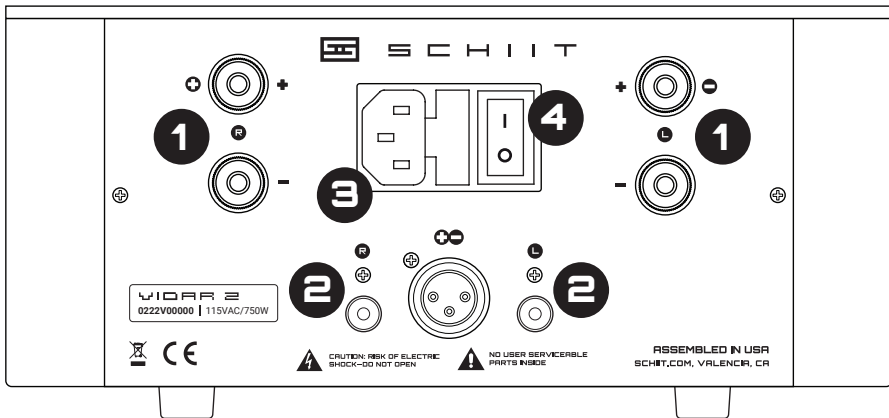

**1 Connect both left and right speakers.** Connect your right speaker to the right red and black output terminals and your left speaker to the left red and black output terminals.

**2 Connect both RCA inputs.** Similarly, connect your source with RCA cables—right into the input marked “R”, and left into the input marked “L”.

**3 Get powered up.** Connect to a wall socket with the provided AC cord. Or you can use any IEC-type cord; ours isn’t special.

**4 Turn on when it’s time for the music.** Up is on. Down is off. Pretty simple. Feel free to leave the amp on all the time if you’d like. You can always put it in Standby using the front panel button.

# MONO CONNECTION

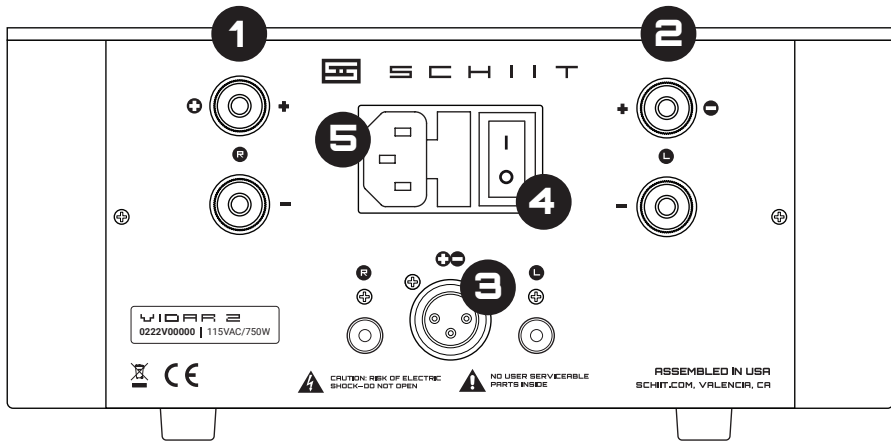

**1 Connect your speaker to the two top red terminals only.** Right is “+”, and left is “-”. Please note both of these are active outputs—do not ground one of them!

**3 Connect a balanced source using a high-quality XLR cable.** It’s important that the preamp is truly balanced for maximum power output.

**4 Get powered up.** Connect to a wall socket with the provided AC cord. Or use any IEC-type cord; ours isn’t special.

**5 Turn on for tunes.** Up is on. Down is off. Pretty simple. Feel free to leave the amp on all the time if you’d like. You can always put it in Standby to save power.

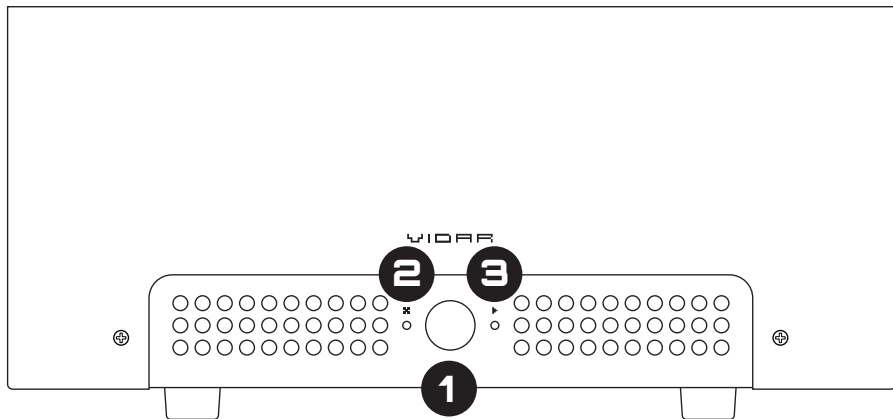

## OPERATION

**1 Press to toggle Standby mode.** When the amp is in Standby mode, it only uses a couple of watts, saving power. You can leave the amp on all the time and just put it in Standby when you're not using it

**2 When lit, this light indicates Standby mode.** When flashing, it indicates that Vidar 2 is getting everything ready to run.\*

**3 When lit, this light indicates normal operation.** When flashing, there's a fault. See the next section for what to do if it's flashing.

\*Vidar 2 or Aegir 2 take about 30 seconds to perform self-checks when first turned on. When coming out of Standby mode, it takes about 60 seconds.

**Okay, so you have a flashing light. Deep breath. We'll get this taken care of shortly.**

When the amp's front lights flash during operation (and the amp mutes), or if it never stops flashing after you turn on the amp, there's a problem, or fault. There are three kinds of faults:

**1. Over-temperature.** The heatsinks are too hot, and the amp has shut down to protect its output. If the amp is very hot, turn it off, wait a while for it to cool down, and try turning it on again. Please note that in some very hot ambient environments (over 80 degrees F), you may need to use an external fan to avoid over-temperature faults.

**2. Over-current.** If the amp is connected to very low-impedance speakers (2 ohms in stereo, or 4 ohms in mono), playing very loud music can cause an over-current condition. Simply turn the amp off and on again to clear this fault.

Alternately, the amplifier may shut off from over-current if the speaker cables are shorted. To troubleshoot this, turn off the amp, disconnect the speaker cables from the amp, and turn it back on again. If it comes back on, there may be a short in your speaker cables (or your speakers). Examine your connections to ensure there are no stray wires or shorts. Once those have been fixed, you can reconnect the speakers and play music again.

**3. High DC offset.** Both Vidar 2 and Aegir 2 are DC-coupled amps. They monitor and corrects DC levels at the output. However, these amps may not always be able to correct for extremely high DC from your source (such as a preamp). To clear this fault, turn off the amp, disconnect the RCA cables or XLR cable from the amp, and turn it back on again. If the amp turns on normally, then there may be high DC on the output of your source. Have the source inspected and repaired.

## WARRANTY

Schiit Audio warrants to the original purchaser that this product shall be free from defects in material and workmanship for five (5) years from the date of purchase. If a defect covered by this warranty occurs during this period, Schiit Audio will repair the defective product, free of charge. Date of purchase will be based on customer receipts, otherwise date of manufacturing will be used.

**If you believe you need warranty service, contact us first.** Schiit Audio products sent back to us without a Return Authorization (RA) will be returned to the sender without repair. To contact us and obtain an RA, email [info@schiiit.com](mailto:info@schiiit.com).

**Warranty Limitations.** This warranty shall not apply if a product: (a) is modified or tampered with; (b) is damaged by negligence, accident, unreasonable use, or other causes unrelated to defective materials or workmanship, or (c) has had the serial number altered or removed.

Any implied warranties, including warranties of merchantability and fitness for a particular purpose, are hereby limited in duration to the warranty period of 5 years. In no event shall Schiit Audio be liable for consequential or incidental damages resulting from the breach of any implied or expressed warranties. Some states do not allow these limitations, so they may not apply to you. You may also have other rights which vary from state to state or province to province.

## IN THE BOX

- (1) Vidar 2 or Aegir 2
- (1) Power Cord
- (0) Class D modules
- (0) Switching supplies
- (Various) Stickers and stuff
- (Infinite) Appreciation from the whole Schiit crew in Valencia, CA and Corpus Christi, TX
- (Even more) Thanks from our chassis and PCB guys in California, Nevada, and Utah.



This product is in compliance with standards and regulations of the European Community.

SCHIIT.COM  
INFO@SCHIIT.COM

